RRD

FRESAS CON PLACA REDONDA
CON GRAN RENDIMIENTO Y AUMENTO DE LA VIDA DE LA
HERRAMIENTA



Mplus...

RRD

CARACTERÍSTICAS DEL PRODUCTO



- Fresa con placa redonda para el mecanizado de moldes y matrices.
- Gama versátil de calidades de placa para el mecanizado de hasta 60 HRC.
- Disponibilidad de un amplio abanico de fresas: frontal, rosca, con mango y Weldon.
- Gran variedad de tamaños de placa: R2.5, 3.5, 5.0, 6.0 y 8.0.

RRD

FRESAS CON PLACA REDONDA

FRESAS RRD



CARACTERÍSTICAS

Las placas están disponibles en tres tolerancias distintas para adaptarse a cualquier aplicación.

RDHX	RDZX	RDMX
<ul style="list-style-type: none"> Rectificado (tolerancia H) Alta precisión Semiacabado y acabado 	<ul style="list-style-type: none"> Sinterización de precisión (tolerancia E) Uso universal Placa económica con una larga vida útil de la herramienta 	<ul style="list-style-type: none"> Sinterización (tolerancia M) Uso universal Desbaste y semiacabado
<p>IC: ± 0.013 mm S1: ± 0.025 mm</p>	<p>IC: ± 0.025 mm S1: ± 0.025 mm</p>	<p>IC: ± 0.05-± 0.15 mm S1: ± 0.13 mm</p>

VISTA GENERAL DE LAS CALIDADES

Resistencia al desgaste ↑	Metal duro con recubrimiento					Metal duro sin recubrimiento	Metal duro con recubrimiento		Metal duro sin recubrimiento	Metal duro con recubrimiento			
	P	VP05HT	VP10H	VP15TF	VP20M	F7030	UT120T	VP15TF	UT120T	H	VP05HT	VP10H	VP15TF
	P01									H01			
	P10									H10			
	P20									H20			
	P30									H30			
Dureza ↓	P40												

RRD N



P K H

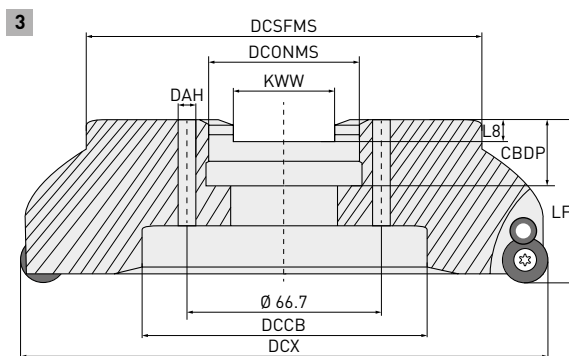
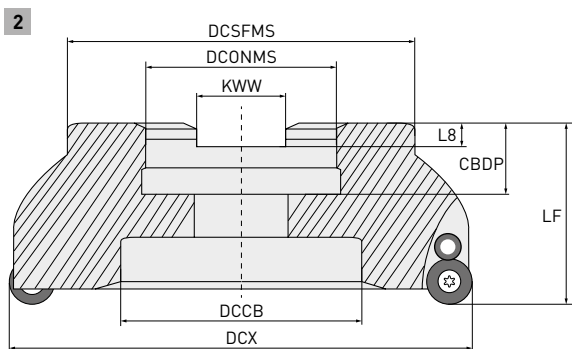
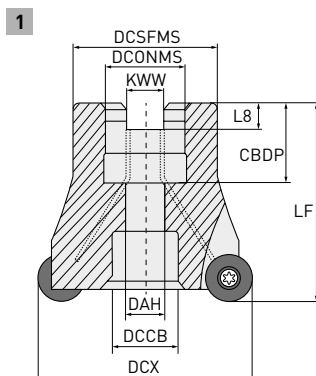

Solo portaherramientas a mano derecha

TIPO FRONTAL (neutro)





Referencia	Stock	APMX	DCX	DC	LF	DCONMS	CBDP	DAH	DCSFMS	KWW	L8	DCCB	ZEFP		Tipo	
RRD050N-042A06R	●	5	42	32	44	16	18	9	33	8.4	5.7	15	6		1	RDH/M/Z 1003M0
RRD050N-052A07R	●	5	52	42	50	22	20	11	44	10.4	6.3	18	7		1	
RRD060N-042A05R	●	6	42	30	42	16	18	9	33	8.4	5.7	15	5		1	
RRD060N-050A05R	●	6	50	38	50	22	20	11	44	10.4	6.3	18	5		1	RDH/M/Z 12T3M0
RRD060N-052A05R	●	6	52	40	50	22	20	11	44	10.4	6.3	18	5		1	
RRD060N-063A06R	●	6	63	51	50	22	20	11	44	10.4	6.3	18	6		1	
RRD080N-050A04R	●	8	50	34	50	22	20	11	44	10.4	6.3	18	4		1	
RRD080N-052A04R	●	8	52	36	50	22	20	11	4	10.4	6.3	18	4		1	
RRD080N-052A05R	●	8	52	36	50	22	20	11	4	10.4	6.3	18	5		1	
RRD080N-063A05R	●	8	63	47	50	22	20	11	4	10.4	6.3	18	5		1	
RRD080N-066A05R	●	8	66	50	50	27	22	13.5	53	12.4	7.2	20	5		1	RDH/M/Z 1604M0
RRD080N-080A06R	●	8	80	64	52	27	22	13.5	64	12.4	7.2	20	6		1	
RRD080N-100A07R	●	8	100	84	52	32	29	—	72	14.4	8	46	7	—	2	
RRD080N-125B08R	●	8	125	109	52	40	30	—	82	16.4	9	58	8	—	2	
RRD080N-160C09R	□	8	160	144	52	40	29	14	90	16.4	9	92	9	—	3	

1/1



RRD N

REPUESTOS

Referencia	RE					
		Placa Brida	Tornillo Brida	Tornillo de placa	Tornillo de sujeción	Llave
RRD050N-	042A06R	5			—	
	052A07R					
RRD060N-	042A05R	6	—	—	B-TS35	TKY15F
	050A05R					
	052A05R					
	063A06R					
RRD080N-	050A04R	8	KS-12	B-TS45	214	—
	052A04R					
	052A05R					
	063A05R					
	066A05R					
	080A06R					
	100A07R					
	125B08R					
160C09R						

RRD P



P K H

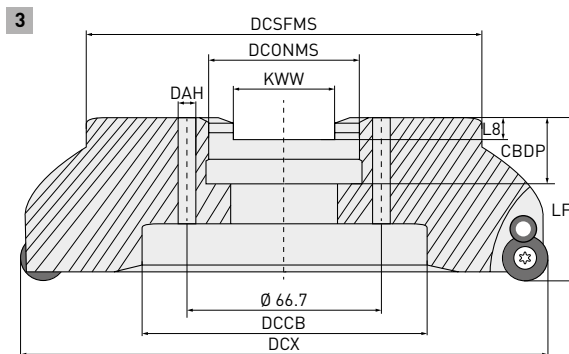
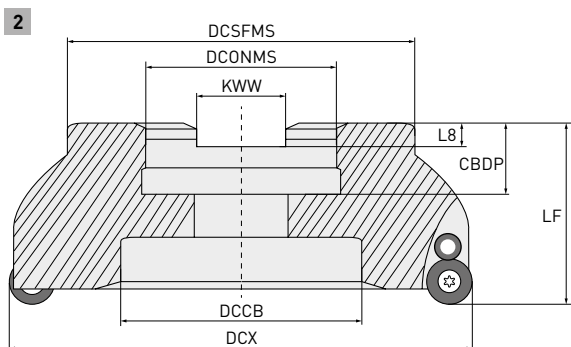
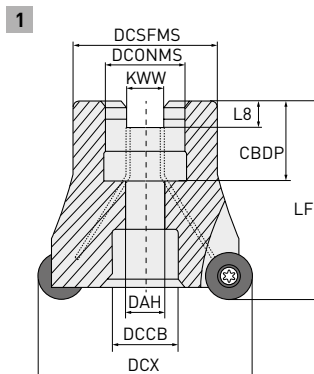

Solo portaherramientas a mano derecha

TIPO FRONTAL (positivo)





Referencia	Stock	APMX	DCX	DC	LF	DCONMS	CBDP	DAH	DCSFMS	KWW	L8	DCCB	ZFP	Tipo
RRD060P-050A05R	●	6	50	38	50	22	20	11	44	10.4	6.3	18	5	1
RRD060P-052A05R	●	6	52	40	50	22	20	11	44	10.4	6.3	18	5	1
RRD060P-063A06R	●	6	63	51	50	22	20	11	44	10.4	6.3	18	6	1
RRD060P-066A06R	●	6	66	54	52	27	22	13.5	53	12.4	7.2	20	6	1
RRD060P-080A07R	●	6	80	68	50	27	22	13.5	64	12.4	7.2	20	7	1
RRD080P-050A04R	●	8	50	34	50	22	20	11	44	10.4	6.3	18	4	1
RRD080P-063A05R	●	8	63	47	50	22	20	11	44	10.4	6.3	18	5	1
RRD080P-066A05R	●	8	66	50	50	27	22	13.5	53	12.4	7.2	20	5	1
RRD080P-080A06R	●	8	80	64	52	27	22	13.5	64	12.4	7.2	20	6	1
RRD080P-100A07R	●	8	100	84	52	32	29	—	72	14.4	8	46	7	2
RRD080P-125B08R	●	8	125	109	52	40	30	—	82	16.4	9	58	8	2
RRD080P-160C09R	●	8	160	144	52	40	29	14	90	16.4	9	92	9	3

1/1



RRD P

REPUESTOS

Referencia	RE						
		Placa Brida	Tornillo Brida	Tornillo de placa	Tornillo de sujeción	Llave	
RRD060P-	050A05R						
	052A05R						
	063A06R	6	—	—	B-TS35	TS1001	TKY15F
	066A06R						
	080A07R						
RRD080P-	050A04R						
	063A05R						
	066A05R						
	080A06R	8	KS-12	B-TS45	214	—	TKY20F
	100A07R						
	125B08R						
160C09R							

RRD



P

K

H

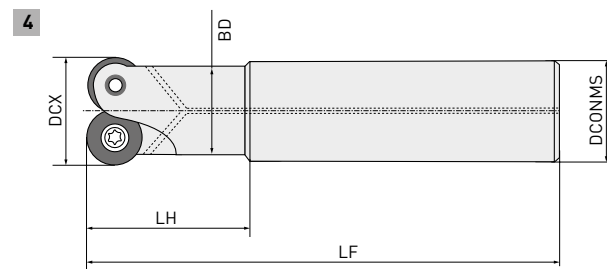
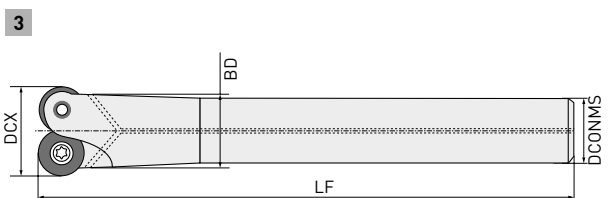
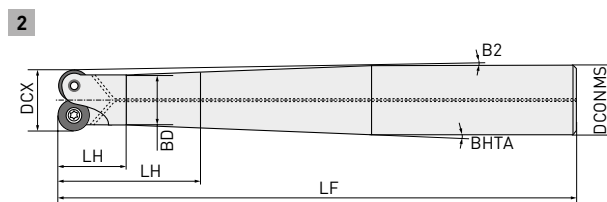
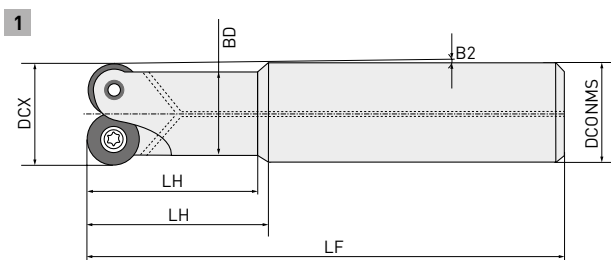

Solo portaherramientas a mano derecha

TIPO MANGO RECTO





Referencia	Stock	APMX	DCX	DCONMS	LF	LU	LH	BD	B2	BHTA	ZEFP		Tipo	
RRD025R102S10Z	●	2.5	10	10	75	—	23	—	—	0.89	2	●	4	RDH/Z 0501M0
RRD025R123S12Z	●	2.5	12	12	75	—	23	11	—	—	3	●	4	
RRD025R154S16Z	●	2.5	15	16	80	22	22.5	14	1.4	45	4	●	1	
RRD035R122S10Z	●	3.5	12	10	75	23	—	11	—	—	2	●	3	RDH/M/Z 07T1M0
RRD035R122S12Z	●	3.5	12	12	75	—	23	11	—	—	2	●	4	
RRD035R122S16Z	□	3.5	12	16	88	15	18.4	11	4	8.37	2	●	2	
RRD035R122S16ZL	●	3.5	12	16	128	15	22.4	11	2.36	3.87	2	●	2	RDH/M/Z 0702M0
RRD035R122S16ZM	●	3.5	12	16	109	15	22.4	11	2.36	3.87	2	●	2	
RRD035R152S16Z	□	3.5	15	16	88	18	27.6	14	1	6.52	2	●	2	
RRD035R152S16ZM	●	3.5	15	16	108	18	41.4	14	0.59	2.69	2	●	2	RDH/M/Z 1003M0
RRD035R152S20Z	●	3.5	15	20	130	20	35.6	14	2.12	4.04	2	●	2	
RRD035R152S20ZM	●	3.5	15	20	150	20	41.7	14	1.64	2.9	2	●	2	
RRD035R152S25Z	□	3.5	15	25	176	20	36.8	14	2.64	3.8	2	●	2	RDH/M/Z 07T1M0
RRD035R153S12Z	□	3.5	15	12	75	17	—	12.8	—	—	3	●	3	
RRD035R153S16Z	□	3.5	15	16	78	29.5	30	14	1.08	45	3	●	1	
RRD050R202S20Z	●	5	20	20	90	—	31	18	—	—	2	●	4	RDH/M/Z 1003M0
RRD050R202S20ZM	●	5	20	20	110	—	51	18	—	—	2	●	4	
RRD050R202S25Z	●	5	20	25	136	68.5	69.5	18	2.13	45	2	●	1	
RRD050R202S25ZL	●	5	20	25	176	108.5	109.5	18	1.34	45	2	●	1	RDH/M/Z 1003M0
RRD050R202S25ZM	●	5	20	25	156	88.5	89.5	18	1.64	45	2	●	1	

1/1



RRD

REPUESTOS

Referencia	RE						
		Placa Brida	Tornillo Brida	Tornillo de placa	Tornillo de sujeción	Llave	
RRD025R-	102S10Z						
	123S12Z	2.5	—	—	B-TS20	—	TKY06F
	54S16Z						
RRD035R-	122S10Z						
	122S12Z						
	122S16Z		—	—	B-TS253	—	TKY07F
	122S16ZL						
	122S16ZM						
	152S16Z	3.5					
	152S16ZM						
	152S20Z		—	—	TS25	—	TKY08F
	152S20ZM						
	152S25Z						
153S12Z		—	—	TS253	—	TKY08F	
153S16Z							
RRD050R-	202S20Z						
	202S20ZM						
	202S25Z	5	—	—	B-TS35	—	TKY15F
	202S25ZL						
	202S25ZM						

RRD



P

K

H

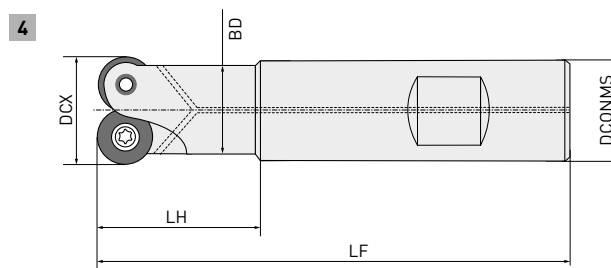
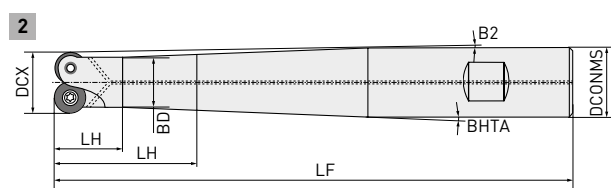
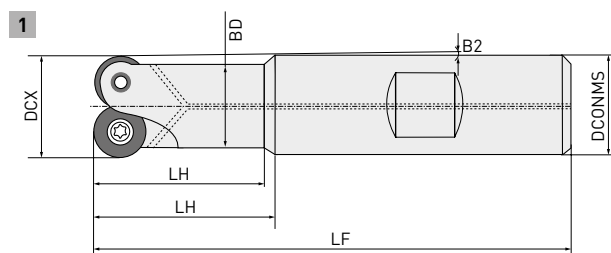

Solo portaherramientas a mano derecha

TIPO MANGO CON WELDON





Referencia	Stock	APMX	DCX	DCONMS	LF	LU	LH	BD	B2	BHTA	ZEFP		Tipo	
RRD035R122S16W	●	3.5	12	16	88	15	18.4	11	4	8.37	2		2	RDH/M/Z 07T1M0
RRD035R122S16WL	●	3.5	12	16	128	15	22.4	11	2.36	3.87	2		2	
RRD035R122S16WM	□	3.5	12	16	108	15	22.4	11	2	3.87	2		2	
RRD035R152S16W	□	3.5	15	16	88	18	27.6	12.8	1	6.52	2		2	RDH/M/Z 0702M0
RRD035R152S16WM	□	3.5	15	16	108	18	41.38	12.8	0.59	2.69	2		2	
RRD035R152S20W	□	3.5	15	20	130	20	35.58	12.8	2.12	4.04	2		2	
RRD035R152S20WM	□	3.5	15	20	150	20	41.7	12.8	1.64	2.9	2		2	RDH/M/Z 07T1M0
RRD035R152S25W	□	3.5	15	25	176	20	36.8	12.8	3.8	2.65	2		2	
RRD035R153S16W	□	3.5	15	16	78	28.4	29.5	12.8	1.08	45	3		1	
RRD050R202S20W	●	5	20	20	90	—	31	18	—	—	2		4	RDH/M/Z 1003M0
RRD050R202S20WM	●	5	20	20	110	—	51	18	—	—	2		4	
RRD050R202S25W	●	5	20	25	136	23	37	18	2.13	4.09	2		2	
RRD050R202S25WL	□	5	20	25	176	47.6	23	18	1.34	2.25	2		2	RDH/M/Z 1003M0
RRD050R202S25WM	□	5	20	25	156	42.7	23	18	1.64	2.9	2		2	

1/1



RRD

REPUESTOS

Referencia	RE						
		Placa Brida	Tornillo Brida	Tornillo de placa	Tornillo de sujeción	Llave	
	122S16W						
	122S16WL	—	—	B-TS253	—	TKY07F	
	122S16WM						
RRD035R-	152S16W						
	152S16WM	3.5					
	152S20W			TS25	—	TKY08F	
	152S20WM	—	—				
	152S25W						
	153S16W			TS253			
RRD050R-	202S20W						
	202S20WM						
	202S25W	5	—	—	B-TS35	—	TKY15F
	202S25WL						
	202S25WM						

RRD



P K H

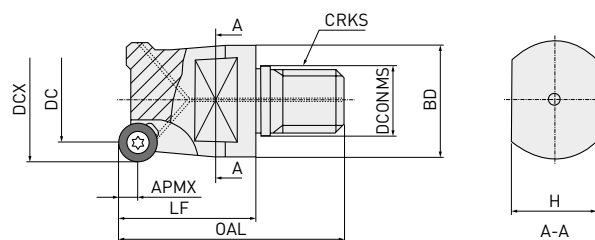

Solo portaherramientas a mano derecha

TIPO ROSCADO





Referencia	Stock	APMX	DCX	DC	OAL	LF	DCONMS	DCSFMS	CRKS	H	ZEPF		
RRD025R102M5	□	2.5	10	5	35	20	5.5	9.9	M5	6	2	●	
RRD025R123M8	●	2.5	12	7	38	20	8.5	13.5	M8	9	3	●	RDH/Z
RRD025R154M8	●	2.5	15	10	38	20	8.5	13.5	M8	10	4	●	0501M0
RRD025R205M10	●	2.5	20	15	44	25	10.5	18	M10	15	5	●	
RRD035R122M8	●	3.5	12	5	46	28	8.5	13.5	M8	9	2	●	
RRD035R153M8	●	3.5	15	8	46	28	8.5	13.5	M8	10	3	●	
RRD035R204M10	●	3.5	20	13	47	28	10.5	18	M10	15	4	●	RDH/M/Z
RRD035R255M12	●	3.5	25	18	50	28	12.5	21	M12	17	5	●	07T1M0
RRD035R306M16	●	3.5	30	23	51	28	17	29	M16	22	6	●	
RRD035R357M16	●	3.5	35	28	51	28	17	29	M16	22	7	●	
RRD035R152M8	●	3.5	15	8	46	28	8.5	13.5	M8	10	2	●	RDH/M/Z
RRD035R153M8X	●	3.5	15	8	43	28	8.5	13.5	M8	10	3	●	0702M0
RRD050R202M10	●	5	20	10	47	28	10.5	18	M10	15	2	●	
RRD050R252M12	●	5	25	15	54	32	12.5	21	M12	17	2	●	
RRD050R253M12	●	5	25	15	54	32	12.5	21	M12	17	3	●	
RRD050R304M12	●	5	30	20	54	32	12.5	21	M12	17	4	●	RDH/M/Z
RRD050R304M16	●	5	30	20	55	32	17	29	M16	22	4	●	1003M0
RRD050R355M16	●	5	35	25	65	42	17	29	M16	22	5	●	
RRD050R426M16	●	5	42	32	65	42	17	29	M16	22	6	●	
RRD060R242M12	●	6	24	12	54	32	12.5	21	M12	17	2	●	
RRD060R353M16	●	6	35	23	65	42	17	29	M16	22	3	●	
RRD060R354M16	●	6	35	23	65	42	17	29	M16	22	4	●	RDH/M/Z
RRD060R424M16	●	6	42	30	55	32	17	29	M16	24	4	●	12T3M0
RRD060R425M16	●	6	42	30	65	42	17	29	M16	22	5	●	
RRD080R322M16	●	8	32	16	65	42	17	29	M16	22	2	●	RDH/M/Z 1604M0

1/1

15

RRD

REPUESTOS

Referencia	RE							
		Placa Brida	Tornillo Brida	Tornillo de placa	Tornillo de sujeción	Llave		
RRD025R-	102M5							
	123M8	2.5	—	—	B-TS20	—	TKY06F	
	154M8							
	205M10							
122M8	3.5							—
153M8								
204M10								
255M12		TKY08F						
306M16								
357M16								
152M8	TKY08F							
153M8X		TS25	—					
RRD050R-	202M10	5	—	—	B-TS35	—	TKY15F	
	252M12							
	253M12							
	304M12							
	304M16							
	355M16							
426M16								
RRD060R-	242M12	6	—	—	B-TS35	—	TKY15F	
	353M16							
	354M16							TS1001
	424M16							
425M16								
RRD080R-	322M16	8	—	—	214	—	TKY20F	

PLACAS

P	Acero	●	●	●	●	●	●				
K	Fundición		✱	✱	●	●	●	✱	Condiciones de corte: ●: Corte continuo ●: Corte general ✱: Corte interrumpido		
H	Materiales endurecidos		●								

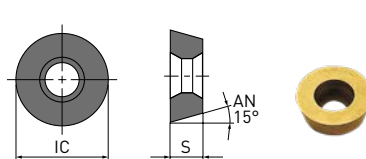
Referencia	Clase	Rectificado	Rectificado						IC	S	Geometría
			F7030	VP15TF	VP20M	VP10H	VP05HT	UTi20T			
RDHX0501M0E	H	E	●	●		●	●	5	1.5	 <p>IC: ±0.013 mm S: ±0.025 mm</p>	
RDHX0501M0S	H	S	●	●		●		5	1.5		
RDHX07T1M0E	H	E	●	●		●	●	7	1.98		
RDHX07T1M0S	H	S	●	●		●	●	7	1.98		
RDHX0702M0E	H	E	●	●		●	●	7	2.38		
RDHX0702M0S	H	S	●	●		●		7	2.38		
RDHX1003M0E	H	E	●	●		●	●	10	3.18		
RDHX1003M0S	H	S	●	●		●	●	10	3.18		
RDHX12T3M0E	H	E	●	●		●	●	12	3.97		
RDHX12T3M0S	H	S	●	●		●		12	3.97		
RDHX1604M0E	H	E	●	●		●	●	16	4.76		
RDHX1604M0S	H	S	●	●		●		16	4.76		
RDMX07T1M0E	M	E					●	7	1.98		
RDMX07T1M0T	M	T	●	●	●			7	1.98		
RDMX0702M0E	M	E					●	7	2.38		
RDMX0702M0T	M	T	●	●	●		□	7	2.38		
RDMX1003M0E	M	E					●	10	3.18		
RDMX1003M0S	M	S		●		●		10	3.18		
RDMX1003M0T	M	T	●	●	●		●	10	3.18		
RDMX12T3M0E	M	E					●	12	3.97		
RDMX12T3M0S	M	S		●		●		12	3.97		
RDMX12T3M0T	M	T	●	●	●		●	12	3.97		
RDMX1604M0E	M	E					●	16	4.76		
RDMX1604M0S	M	S		●		●		16	4.76		
RDMX1604M0T	M	T	●	●	●		●	16	4.76		
RDZX0501M0E	Z	E		●				5	1.50		
RDZX07T1M0E	Z	E		●				7	1.98		
RDZX0702M0E	Z	E		●				7	2.38		
RDZX1003M0E	Z	E		●				10	3.18		
RDZX1003M0S	Z	S	●	●				10	3.18		
RDZX12T3M0E	Z	E		●				12	3.97		
RDZX12T3M0S	Z	S	●	●				12	3.97		
RDZX1604M0E	Z	E		●				16	4.76		
RDZX1604M0S	Z	S	●	●				16	4.76		

PREPARACIÓN DEL FILO DE CORTE

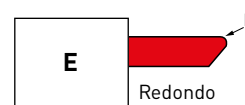
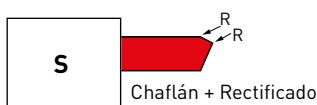

● Para desbaste

●● Para desbaste y acabado

● Para acabado

RRD

CONDICIONES DE CORTE RECOMENDADAS

CONDICIONES DE CORTE PARA DESBASTE (ae = 50 % de Ø)

Material de trabajo	Dureza	Calidad	Vc	Ø 10 - 15 mm		Ø 20 mm		Ø 24 - 25 mm		Ø 30 - 42 mm		Ø 50 - 80 mm		Ø 100 - 160 mm	
				ap	fz	ap	fz	ap	fz	ap	fz	ap	fz	ap	fz
P Acero dulce	<180HB	F7030 VP15TF	(250 - 320)	-0.2	0.25	-0.5	0.45	-1.0	0.35	-1.0	0.40	-1.0	0.50	-1.5	0.60
			(240 - 300)	0.2-0.3	0.20	0.5-1.0	0.25	1.0-2.0	0.30	1.5-2.0	0.32	1.0-1.5	0.40	1.5-2.5	0.45
			(200 - 280)	0.3-0.5	0.12	1.0-1.5	0.15	2.0-2.5	0.20	2.0-3.0	0.25	1.5-3.0	0.35	2.5-5.0	0.35
Acero al carbono Acero aleado	180 - 350HB	F7030 VP15TF	(220 - 300)	-0.2	0.20	-0.5	0.40	-1.0	0.30	-1.0	0.40	-1.0	0.50	-1.5	0.55
			(200 - 290)	0.2-0.3	0.15	0.5-1.0	0.20	1.0-1.5	0.25	1.5-2.0	0.30	1.0-1.5	0.38	1.5-2.5	0.40
			(160 - 250)	0.3-0.5	0.10	1.0-1.5	0.10	1.5-2.0	0.22	2.0-3.0	0.22	1.5-3.0	0.30	2.5-4.5	0.32
K Fundición	Resistencia a la tracción <450 MPa	VP15TF VP20M VP10H	(200 - 250)	-0.1	0.15	-0.5	0.18	-1.0	0.20	-1.0	0.25	-1.0	0.30	-1.5	0.35
			(180 - 230)	0.1-0.2	0.10	0.5-1.0	0.10	1.0-1.5	0.15	1.5-2.0	0.18	1.0-1.5	0.25	1.5-2.5	0.22
			(160 - 200)	0.2-0.25	0.10	1.0-1.5	0.10	1.5-2.0	0.12	2.0-3.0	0.15	1.5-3.0	0.18	2.5-4.5	0.20
H Acero endurecido	-52HRC -58HRC -60HRC	VP15TF VP10H VP05HT	(140 - 200)	-0.1	0.12	-0.1	0.14	-0.1	0.15	-0.1	0.18	-0.1	0.18	-0.1	0.20
			(110 - 180)	0.1-0.15	0.10	0.1-0.20	0.12	0.1-0.30	0.12	0.1-0.30	0.14	0.1-0.30	0.14	0.1-0.30	0.15
			(100 - 170)	0.1-0.15	0.10	0.1-0.20	0.10	0.1-0.30	0.10	0.1-0.30	0.12	0.1-0.30	0.12	0.1-0.30	0.12

1/1

1. Al utilizar una anchura de corte máxima, las condiciones de corte deben reducirse en un 20 %.
2. Al utilizar un mango largo, la velocidad de avance debe reducirse en un 20 %.

CONDICIONES DE CORTE PARA ACABADO (ae = 20 % de Ø)

Material de trabajo	Dureza	Calidad	Vc	Ø 10 - 15 mm		Ø 20 mm		Ø 24 - 25 mm		Ø 30 - 42 mm		Ø 50 - 80 mm		Ø 100 - 160 mm	
				ap	fz	ap	fz	ap	fz	ap	fz	ap	fz	ap	fz
P Acero dulce	<180HB	F7030 VP15TF	(260 - 360)	-0.1	0.15	-0.15	0.20	-0.15	0.25	-0.15	0.30	-0.15	0.32	-0.3	0.35
			(240 - 320)	0.1-0.2	0.15	0.1-0.2	0.15	0.1-0.2	0.18	0.1-0.3	0.20	0.1-0.3	0.22	0.2-0.3	0.25
			(220 - 280)	0.2-0.24	0.10	0.1-0.30	0.15	0.1-0.30	0.18	0.1-0.30	0.20	0.2-0.30	0.20	0.3-0.40	0.20
Acero al carbono Acero aleado	180 - 350HB	F7030 VP15TF	(250 - 350)	-0.1	0.12	-0.1	0.15	-0.1	0.18	-0.1	0.25	-0.1	0.28	-0.15	0.30
			(230 - 310)	0.1-0.15	0.12	0.1-0.30	0.15	0.1-0.30	0.15	0.1-0.30	0.20	0.1-0.3	0.22	0.15-0.3	0.25
			(210 - 270)	0.15-0.2	0.10	0.15-0.30	0.12	0.15-0.30	0.15	0.15-0.30	0.15	0.2-0.3	0.18	0.2-0.3	0.18
K Fundición	Resistencia a la tracción <450 MPa	VP15TF VP20M VP10H	(200 - 300)	-0.1	0.15	-0.1	0.18	-0.1	0.20	-0.1	0.22	-0.1	0.25	-0.15	0.30
			(200 - 280)	0.1-0.2	0.10	0.1-0.30	0.10	0.1-0.3	0.15	0.1-0.3	0.15	0.1-0.3	0.20	0.15-0.3	0.22
			(180 - 240)	0.2-0.25	0.10	0.2-0.40	0.10	0.2-0.4	0.12	0.2-0.4	0.12	0.2-0.4	0.15	0.2-0.4	0.18
H Acero endurecido	-52HRC -58HRC -60HRC	VP15TF VP10H VP05HT	(150 - 200)	-0.1	0.15	-0.1	0.14	-0.1	0.15	-0.1	0.18	-0.1	0.18	-0.1	0.20
			(120 - 180)	0.1-0.15	0.10	0.1-0.20	0.12	0.1-0.30	0.12	0.1-0.30	0.14	0.1-0.30	0.14	0.1-0.30	0.15
			(100 - 180)	0.1-0.15	0.10	0.1-0.20	0.10	0.1-0.30	0.10	0.1-0.30	0.12	0.1-0.30	0.12	0.1-0.30	0.12

1/1

1. Al utilizar una anchura de corte máxima, las condiciones de corte deben reducirse en un 20 %.
2. Al utilizar un mango largo, la velocidad de avance debe reducirse en un 20 %.

RED DE VENTAS EN EUROPA DE MITSUBISHI MATERIALS

GERMANY

MITSUBISHI MATERIALS TOOLS EUROPE GMBH
Comeniusstr. 2 . 40670 Meerbusch
Phone +49 2159 91890 . Fax +49 2159 918966
Email admin@mmchg.de

UK Office

MMC HARDMETAL UK LTD
1 Centurion Court, Centurion Way
Tamworth, B77 5PN
Phone +44 1827 312312
Email sales@mitsubishicarbide.co.uk

UK Deliveries / Returns

Unit 4 B5K Business Park, Quartz Close
Tamworth, B77 4GR

SPAIN

MITSUBISHI MATERIALS ESPAÑA, S.A.
Calle Emperador 2 . 46136 Museros /Valencia
Phone +34 96 1441711
Email comercial@mmevalencia.es

FRANCE

MMC METAL FRANCE S.A.R.L.
6, Rue Jacques Monod . 91400 Orsay
Phone +33 1 69 35 53 53 . Fax +33 1 69 35 53 50
Email mmfsales@mmc-metal-france.fr

POLAND

MMC HARDMETAL POLAND SP. Z O.O
Al. Armii Krajowej 61 . 50-541 Wrocław
Phone +48 71335 1620 . Fax +48 71335 1621
Email sales@mitsubishicarbide.com.pl

ITALY

MMC ITALIA S.R.L.
Viale Certosa 144 . 20156 Milano
Phone +39 0293 77031 . Fax +39 0293 589093
Email info@mmc-italia.it

TURKEY

MITSUBISHI MATERIALS TOOLS EUROPE GMBH ALMANYA İZMİR MERKEZ ŞUBESİ
Adalet Mahallesi Anadolu Caddesi No: 41-1 . 15001 35530 Bayraklı / İzmir
Phone +90 232 5015000 . Fax +90 232 5015007
Email info@mmchg.com.tr

europe.mmc-carbide.com

DISTRIBUIDO POR:

┌

┐

└

┘

MP109S 

Publicado por:  MITSUBISHI MATERIALS TOOLS EUROPE | 2024.01